

# Comparator Gauge **Compika**

*Käfer*



Your partner for highest precision.

## Comparator Gauges Compika

The Comparator Gauges Compika offer a high degree of security and precision. They are based on a solid and well thought-out construction taking into account the latest technology. They are manufactured by the most up-to-date methods.

The following quality features characterize our manufacturing programme of Comparator Gauges Compika:

- Their design conforms to the requirements of DIN 879-1. This applies not only to the dimensions but also to permitted spans of error, hysteresis and measuring pressure.
- Effective shockproof system.
- Pinions and shafts of the movement are jewelled.
- After removal of the safety cap the adjustment screw on top of the case allows simple and safe zero setting of the instrument over the total measuring range.
- A safety cap prevents unintentional turning of the fine adjustment facility.
- Stem and spindle are made of hardened stainless steel.
- The measuring spindles are very sensitive on account of their accurate guides.
- Additional overtravel assists with the insertion of workpieces into the measuring device.
- The clear scale is shadow free.
- The red tolerance markers are easy to recognize and to set.
- On request all models are available with a reduced measuring force of 0.5 N.

### Summary of important technical details of Comparator Gauges Compika

Metric models	Reading	Range	Dial reading	Overtravel	Special feature
Compika 101, 101 B	0.01 mm	0.5 mm	25-0-25	2.5 mm	Shockproof
Compika 101 wa	0.01 mm	0.5 mm	25-0-25	2.5 mm	Water Protected
Compika 505, 505 B	0.005 mm	0.2 mm	100-0-100	2.8 mm	Shockproof
Compika 502, 502 B	0.002 mm	0.2 mm	100-0-100	2.8 mm	Shockproof
Compika 1001, 1001 B	0.001 mm	0.1 mm	50-0-50	3.0 mm	Shockproof
Compika 1001 wa	0.001 mm	0.1 mm	50-0-50	3.0 mm	Water Protected
Inch models	Reading	Range	Dial reading	Overtravel	Special feature
Compika 105 Z, 105 BZ	.0005"	.020"	10-0-10	.10"	Shockproof
Compika 502 Z, 502 BZ	.0002"	.008"	40-0-40	.11"	Shockproof
Compika 501 Z, 501 BZ	.0001"	.008"	40-0-40	.11"	Shockproof
Compika 1005 Z, 1005 BZ	.00005"	.004"	20-0-20	.12"	Shockproof

Models with order code ‚B‘ have shortened measuring spindles. These can be used in most precision inside measuring instruments or measuring devices available on the market today.

## Comparator Gauge Compika 1001

shockproof, with overtravel

The Comparator Gauge Compika 1001 is manufactured conforming to DIN 879-1. The precisely guided measuring spindle and the use of selected materials make the Comparator Gauge Compika 1001 extremely wear-resistant.

Stem and spindle are made of resistant stainless steel.

Comparator Gauge Compika 1001 shockproof, with overtravel	
Reading	0.001 mm
Range	0.1 mm
Dial reading	50-0-50
Bezel-Ø	62 mm
Stem-Ø	8 h 6
Dimensions and accuracy according to	DIN 879-1
Initial measuring force	1.0 N ± 20%
Dimensioned drawing	page 88



Model shown: Compika 1001

## Comparator Gauge Compika 1001 B

shockproof, with overtravel

The Comparator Gauge Compika 1001 B is identical to the model Compika 1001 except for the reduced protrusion of the measuring spindle beyond the stem of 6 mm instead of 14 mm. This gauge fits most precision inside measuring instruments and measuring devices available on the market.

Stem and spindle are made of resistant stainless steel.

Comparator Gauge Compika 1001 B shockproof, with overtravel	
Reading	0.001 mm
Range	0.1 mm
Dial reading	50-0-50
Bezel-Ø	62 mm
Stem-Ø	8 h 6
Dimensions and accuracy according to	DIN 879-1
Initial measuring force	1.0 N ± 20%
Dimensioned drawing	on request

On request the Comparator Gauges Compika are also available with special fittings:

- **Comparator Gauge Compika** with measuring force reduced to 0.5 N
- **Comparator Gauge Compika** with increased measuring force
- **Comparator Gauge Compika** with special dial
- **Comparator Gauge Compika** with stem length 85 mm

Please request our offers.

## Comparator Gauge Compika 1001 wa

water protected, shockproof, with overtravel

The use of a water protected Comparator Gauge is recommended for applications in splash water environments. This version, conforming to protection class IP 53, features the following:

- A flexible rubber bellows is fitted where the spindle enters the stem.
- The back is sealed with a rubber ring.



Comparator Gauge Compika 1001 wa water protected	
Reading	0.001 mm
Range	0.1 mm
Dial reading	50-0-50
Bezel-Ø	62 mm
Stem-Ø	8 h 6
Dimensions and accuracy according to	DIN 879-1
Initial measuring force	1.1 N ± 20%
Dimensioned drawing	page 87

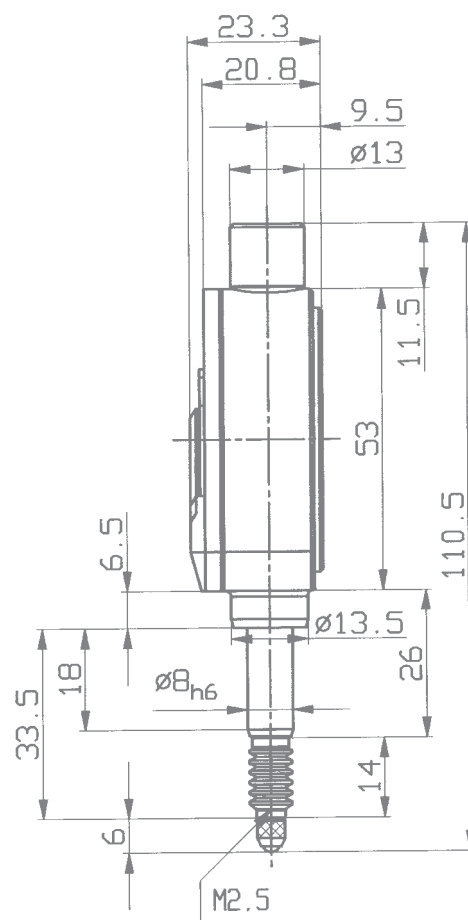

## Comparator Gauge Compika 1005 Z

shockproof, with overtravel

The Comparator Gauge Compika 1005 Z is manufactured conforming to DIN 879-1.

The precisely guided measuring spindle and the use of selected materials make the Comparator Gauge Compika 1005 Z extremely wear-resistant.

Stem and spindle are made of resistant stainless steel.

Comparator Gauge Compika 1005 Z shockproof, with overtravel	
Reading	.00005"
Range	.004"
Dial reading	20-0-20
Bezel-Ø	2.44"
Stem-Ø	8 h 6
Dimensions and accuracy according to	DIN 879-1
Initial measuring force	1.0 N ± 20%
Dimensioned drawing	page 88



Model shown: Compika 1005 Z

## Comparator Gauge Compika 501 Z

shockproof, with overtravel

Comparator Gauges with Inch reading are also available as short version B. They have a measuring spindle shortened by 8 mm to protrude 6 mm beyond the stem. These gauges fit most precision inside measuring instruments and measuring devices available on the market.

Stem and spindle are made of resistant stainless steel.

Comparator Gauge Compika 501 Z shockproof, with overtravel	
Reading	.0001"
Range	.008"
Dial reading	40-0-40
Bezel-Ø	2.44"
Stem-Ø	8 h 6
Dimensions and accuracy according to	DIN 879-1
Initial measuring force	1.0 N ± 20%
Dimensioned drawing	page 88

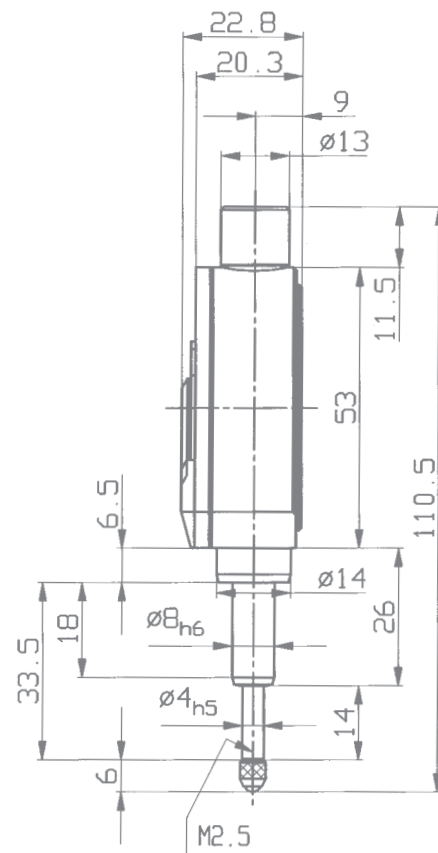

## Description of icon specifications

### Standard fittings

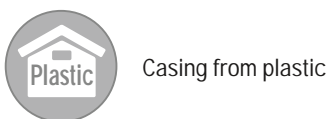
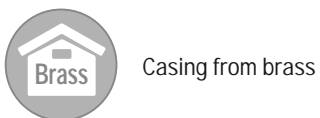
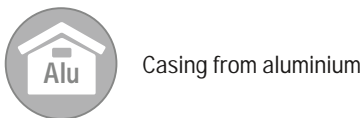
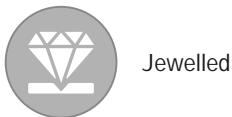

### Special fittings

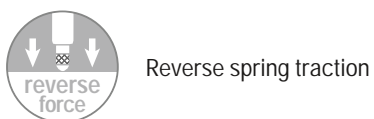
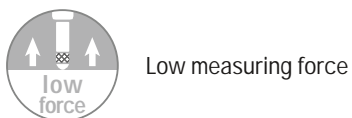
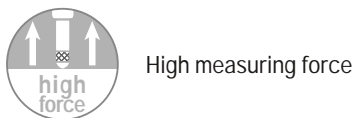
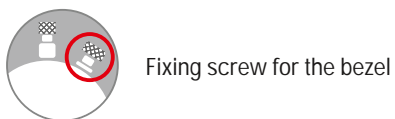

# Precision Dial Gauges



Käfer Messuhrenfabrik GmbH & Co. KG  
Hahnstraße 11  
D-78054 Villingen-Schwenningen

Factory and administration:  
Hahnstraße 11  
78054 Villingen-Schwenningen  
Phone: +49 (0) 7720/8341-0  
Fax: +49 (0) 7720/21868  
E-Mail: [info@kaefer-messuhren.de](mailto:info@kaefer-messuhren.de)  
Internet: [www.kaefer-messuhren.de](http://www.kaefer-messuhren.de)

Your partner for highest precision.